



- -20-100°C Operating Temperature
- Temperature Sensor - .1C Resolution
- Accuracy - .5C (FS)
- Overmolded NTC probe
- IP67
- Media – Liquid, Air, & Gas

### DESCRIPTION

The PTS21 temperature sensor was specifically designed for temperature applications in residential and commercial pools, and solar systems. The overmolded glass encapsulated NTC allows for protection against water ingress that cause traditional temperature sensors to fail. The low cost semi-automated united states manufacturing process allows for a cost effective solution. This sensor can be used with PentAir, Jandy, and Zodiac systems.

### APPLICATIONS

- Pools
- HVAC
- Solar Systems

## Maximum Environmental Ratings

Operating Temperature ..... -20°C to 100°C

Storage Temperature Range ..... -25°C to 125°C

## Installation Instructions

### Water Temperature Sensor Replacement

1. Find the old Water Sensor located between the filter pump and the filter. Remove old Sensor and position the hose clamp over the new Sensor, and gently tighten around pipe.  
**Caution: Do not overtighten clamp.**
2. Feed the cable up through the low voltage compartment of the Load/Power Center to the Control Panel. Strip wires 1/4 in. and connect Sensor wires to WATER screw terminals.

### Solar Temperature Sensor

1. For unglazed panels, fasten Sensor next to solar panels. For glazed panels, suspend Sensor between collector and glazing.
2. Feed the cable up through the low voltage compartment of the Load/Power Center to the Control Panel. Strip wires 1/4" and connect Sensor wires to the Solar screw terminals.

### Ambient Air Temperature (Freeze Protection) Sensor

1. Mount sensor in open air, in shaded area, away from air conditioners. Feed the cable up through the low voltage compartment of the Load/Power Center to the Control Panel, fastening to plumbing with cable ties. Strip wires 1/4 in. and connect Sensor wires to Air screw terminals.

## Mechanical Dimensions (mm),

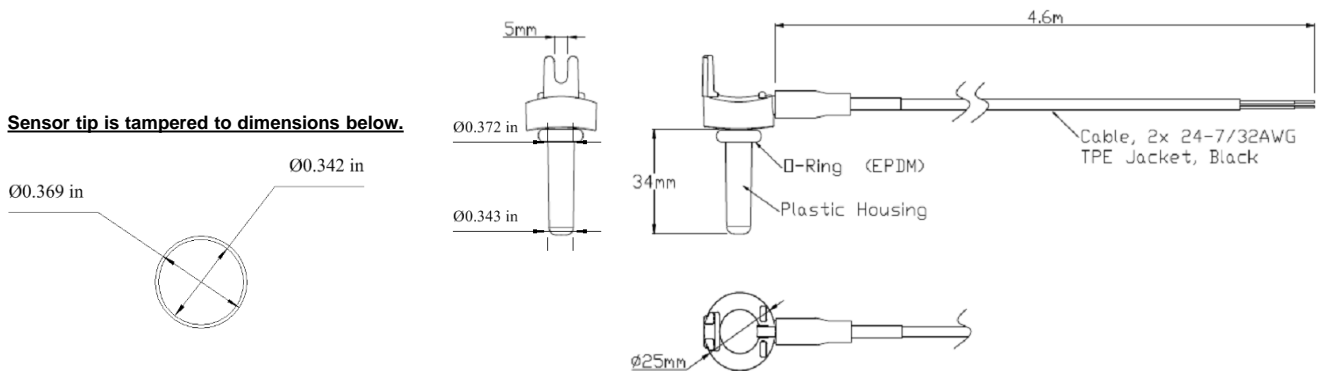

# PTS21- 0

Model

Cable Length (0=40", 1= 240", 2= Custom)

Ph: (480)269-1665 [sales@PhoenixSensors.com](mailto:sales@PhoenixSensors.com)

#### Notice:

Phoenix Sensors LLC reserves the right to make changes to the product contained in this publication. Phoenix Sensors LLC assumes no responsibility for the use of any circuits described herein, conveys no license under any patent or other right, and makes no representation that the circuits are free of patent infringement. While the information in this publication has been checked, no responsibility, however, is assumed for inaccuracies.

Phoenix Sensors LLC does not recommend the use of any of its products in life support applications where the failure or malfunction of the product can reasonably be expected to cause failure of a life-support system or to significantly affect its safety or effectiveness. Products are not authorized for use in such applications.

PTS21 Rev. 2 Aug 2010