



WEPS03 Series



- Low Pressure Wireless
- -20-85°C Operating Temperature
- Compact Size
- Total Error Band 1%
- BLE & 900Mhz Wireless Communication
- 3”H20- 300PSI pressure ranges
- Absolute, Gauge, Vacuum
- Media – Air, High Humidity, & Gas
- IP55 (IP65 available)
- 200-350 Ft wireless range

DESCRIPTION

The WEPS03 is a Bluetooth or 900Mhz wireless pressure sensor manufactured for simple measurements on a variety of applications. This silicon pressure sensor was designed to supply an economical solution for industrial, consumer, and commercial applications.

Simply download the Phoenix Sensors BLE application from our website and connect to the device. Or have full connectivity through the web by purchasing the 900Mhz option and the PS9W (WIFI) unit. The sensor will shut down automatically when it is not in use to preserve the battery. The battery version will last up to 2 years in continuous (1 measurement/60 sec) use. Please contact us for Custom design availability.

The Mobile Software enables you to see the data (via BLE or 900Mhz) immediately and the Online backend allows users to store data for months or even years for evaluation later. Update rates can range from once a second to once every day.

APPLICATIONS

- Consumer products
- Industrial Automation
- HVAC
- Pool Pumps
- Compressor
- Pneumatics

Maximum Environmental Ratings

Operating Temperature -20°C to 85°C
 Storage Temperature Range -40°C to 85°C

Proof pressure 2x full scale pressure
 Burst pressure 3x full scale pressure

Liquid Level – Trucks, Gas/Water Tanks

The WEPS03 is a wireless pressure sensor used in a variety of liquid level applications, such as Water Trucks, Liquid Tanks, Oil tanks, and Spas. The sensor can measure down to 1" of H₂O.



HVAC – High & Low Side of A/C



The WEPS03 is a wireless pressure sensor that can measure up to pressures of 500PSI. It is accurate and robust enough for HVAC applications; if you need temporary remote Pressure and Temperature measurement of the system this sensor is your solution.

Air Compressors

The WEPS03 is a wireless pressure sensor that can measure up to pressures of 500PSI, so it is ideal for most air compressor applications. For troubleshooting, the WEPS03 offers temporary remote Pressure and Temperature measurement of the system. The battery powered solution can last up to 12-months of continuous (1 measurement/10 seconds) use.



Pumps – Water, Hydraulic, etc.



The WEPS03 is a wireless pressure sensor that can measure up to pressures of 500PSI, so it is ideal for Pump applications. For monitoring, the WEPS03 offers temporary remote Pressure measurement of the system. The battery powered solution can last up to 18-months of continuous (1 measurement/30 seconds) use.

WEPS03 Operational Characteristics

$V_+ = 5V$, $V_- = 0V$, Temperature = 25°C

PARAMETER	SYMBOL	MIN	TYP	MAX	UNITS
Supply Voltage (note 1)	V_{DD}	2.2	3	3.5	V
Supply Current	I_{DD}	5	50	750	uA
Wireless Digital Output (BLE or 900Mhz)	BLE/900Mhz				
Linearity (Note 2)		-0.25		0.25	%FS
Temperature Error (Null and Span) (Note 3)		-1		+1	C
Response Time	t_R		5	500	ms
Total Error Band (Note 4)		-1		1	%FS
Compensated Temperature Range	C	0		50	C
Operating Temperature Range	C	-20		85	C

Notes:

1) Battery & Rechargeable Version - 3V battery operation 2) Defined as best straight line 3) Measured from 0°C to 50°C 4) Measured over compensated temperature range -10-50C

Application Information

Package

The two piece body design is made of industrial high-temperature plastic, which allows for easy low-cost manufacturability and corrosion resistance. Vibration resistant design for use in industrial applications. Other materials for the housing are an option for custom OEM designs

Stability

The silicon MEMS pressure sensor element is mounted to a ceramic base and sealed into the plastic housng. The brass barb fittings are utilized to connect to the application. The selection of thermally capability materials reduce the mechanical stress on the sensor resulting in greater stability over time and temperature.

Additional stability is gained from factory stabilization of all sensors.

Pressure port

1/8" brass barb fitting, 1/8"-Plastic Barb fitting and 1/8"-SS barb fittings are standard options. Other port fittings such as 1/8" Plastic Union fitting, and 1/4" brass barb fitting are available for OEM customers.

Media

The pressure port is tolerant to most media including but not limited to oil, air, gas, and non-corrosive media. Sensor will only work on a temporary basis in any non-air application. Sensor will need to have a period of time to dehydrate.

Wetted parts

When checking media capability, the wetted surface is composed of Aluminum and Silicon Gel.

Pressure ranges

Standard pressure ranges are 1, 5, 30, 50, 100, 150, and 300 psi in absolute and gage. Custom pressure ranges are available for OEM customers.

Mechanical Dimensions (inches)

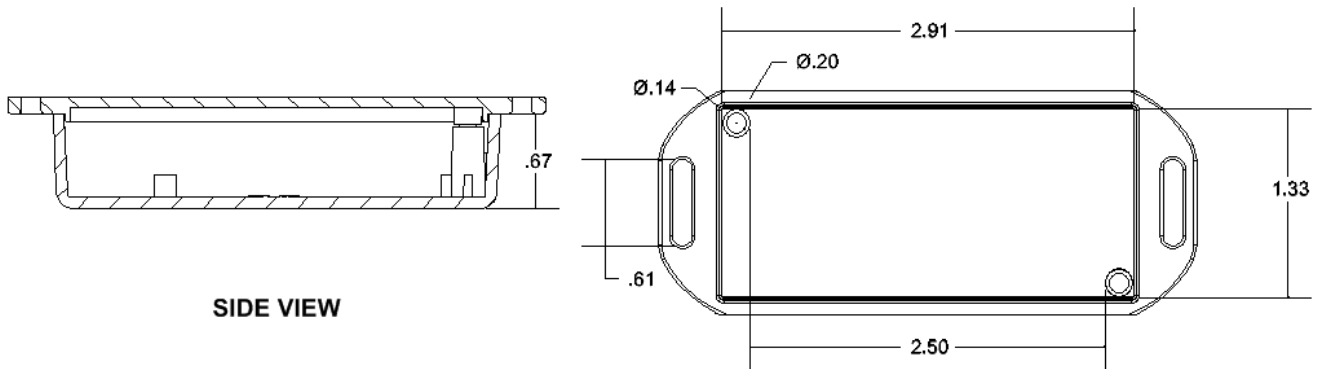

Pic. 1 - Battery Option

Part Number Configuration

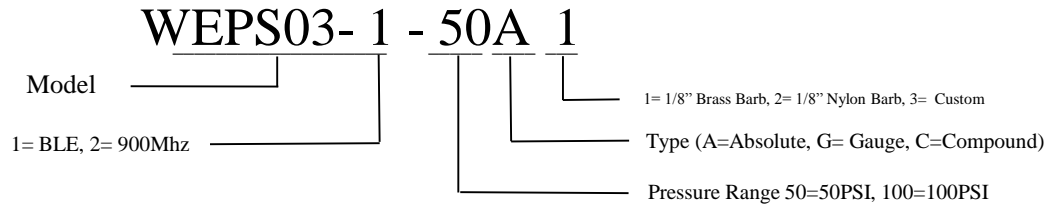

Standard Part Numbers

Model	Pressure Range PSI	Type	Max Over Pressure
WEPS03-0-50A1	50	Absolute	150
WEPS03-0-100A1	100	Absolute	200
WEPS03-0-300A1	300	Absolute	450

Ph: (480) 269-1665 sales@PhoenixSensors.com

Notice:

Phoenix Sensors LLC reserves the right to make changes to the product contained in this publication. Phoenix Sensors LLC assumes no responsibility for the use of any circuits described herein, conveys no license under any patent or other right, and makes no representation that the circuits are free of patent infringement. While the information in this publication has been checked, no responsibility, however, is assumed for inaccuracies.

Phoenix Sensors LLC does not recommend the use of any of its products in life support applications where the failure or malfunction of the product can reasonably be expected to cause failure of a life-support system or to significantly affect its safety or effectiveness. Products are not authorized for use in such applications.