



WEPS05 Series



- Wide Pressure Range
- -20-85°C Operating Temperature
- -40-125C Sensor Operating Temperature
- Compact Size
- Total Error Band 1%
- 900Mhz Wireless Communication
- 10-10,000 psi pressure ranges
- Absolute, Gauge, Vacuum
- Media – Liquid, Air, & Gas
- 300Ft Range
- IP55 Housing (& IP65 [Nema 4x] Industrial)

DESCRIPTION

The WEPS05 is a 900Mhz wireless pressure sensor manufactured for simple measurements on a variety of applications. This system can use Phoenix Sensors various pressure sensors to supply the appropriate solution for industrial, consumer, and commercial applications.

Simply setup the Phoenix Sensors back-end Online and Mobile application from our website and connect to the device. The sensor will go into sleep-mode (low-power) when it is not in use to preserve the battery. The battery version will last up to 2 years in continuous (1 measurement/30 sec) use. Please contact us for Custom design availability.

The Mobile Software enables the user to store data to the cloud for evaluate later. Custom sensor solutions include on-board memory stores up to 300 hours of data for troubleshooting or evaluation of system pressure and/or temperature.

APPLICATIONS

- Water Pump Systems
- Industrial Automation
- HVAC
- Pool Pumps
- Compressor
- Pneumatics
- Hydraulic Systems

Maximum Environmental Ratings

Operating Temperature -20°C to 85°C
 Storage Temperature Range -40°C to 85°C

Proof pressure 2x full scale pressure
 Burst pressure 3x full scale pressure (Max 12kPSI)

Liquid Level – Trucks, Gas/Water Tanks

The WEPS05 is a wireless pressure sensor used in a variety of liquid level applications, such as Water Trucks, Liquid Tanks, Oil tanks, and Spas. It can measure down to 1” of H2O



HVAC – High & Low Side of A/C



The WEPS05 is a wireless pressure sensor that can measure up to pressures of 500PSI. It is accurate and robust enough for HVAC applications; if you need temporary remote Pressure and Temperature measurement of the system this sensor is your solution.

Air Compressors

The WEPS05 is a wireless pressure sensor that can measure up to pressures of 500PSI, so it is ideal for most air compressor applications. For troubleshooting, the WEPS05 offers temporary remote Pressure and Temperature measurement of the system. The battery powered solution can last up to 12-months of continuous (1 measurement/10 seconds) use.



Pumps – Water, Hydraulic, etc.



The WEPS05 is a wireless pressure sensor that can measure up to pressures of 500PSI, so it is ideal for Pump applications. For monitoring, the WEPS05 offers temporary remote Pressure measurement of the system. The battery powered solution can last up to 18-months of continuous (1 measurement/30 seconds) use.

WEPS05 Operational Characteristics

$V_+ = 5V$, $V_- = 0V$, Temperature = 25°C

PARAMETER	SYMBOL	MIN	TYP	MAX	UNITS
Supply Voltage (note 1)	V_{DD}	2.2	3	3.5	V
Supply Current	I_{DD}	5	50	750	uA
Wireless Digital Output (BLE)	BLE				
Linearity (Note 2)		-0.25		0.25	%FS
Temperature Error (Null and Span) (Note 3)		-1		+1	C
Response Time	t_R		5	500	ms
Total Error Band (Note 4)		-1		1	%FS
Compensated Temperature Range	C	-10		70	C
Sensor Operating Temperature Range	C	-40		125	C
Wireless Housing Operating Temp.	C	-20		85	C

Notes:

1) Battery & Rechargeable Version - 3V battery operation 2) Defined as best straight line 3) Measured from 0°C to 70°C 4) Measured over compensated temperature range -10-70C

Application Information

Package

The two piece sensor body design is made of SS316, which allows for easy low-cost manufacturability and corrosion resistance. Vibration proof design for use in industrial applications. Plastic option is available for custom designs

Stability

The silicon MEMS pressure transducer is mounted to a SS base and sealed into the SS316 housing. The selection of thermally capability materials reduce the mechanical stress on the sensor resulting in greater stability over time and temperature.

Additional stability is gained from factory stabilization of all sensors.

Pressure port

1/4" -18NPT and 1/8"-18NPT threads are standard SS fittings. Other port fittings such as 7/16-20UNF, and 1/4" BSP are available for OEM customers.

Media

The pressure port is tolerant to most media including but not limited to oil, air, gas, and any media compatible with 17-4PH or 316L. We do have other material options such as Inconel and Titanium for OEM customers.

Wetted parts

When checking media capability, the wetted surface is composed of Stainless Steel (316L or 17-4PH).

Pressure ranges

Standard pressure ranges are 15, 30, 50, 100, 150, 300, 1k, 3k, and 5k psi in absolute and gage. Custom pressure ranges are available for OEM customers.

Mechanical Dimensions (inches)

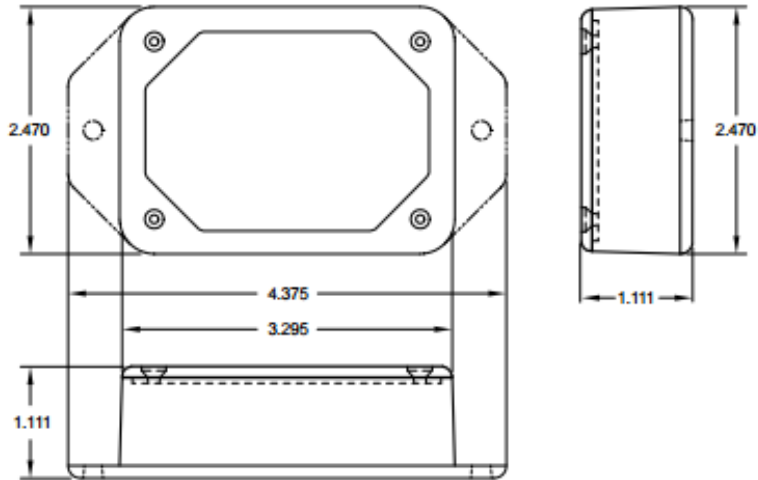

Pic. 1 - Standard Housing IP55

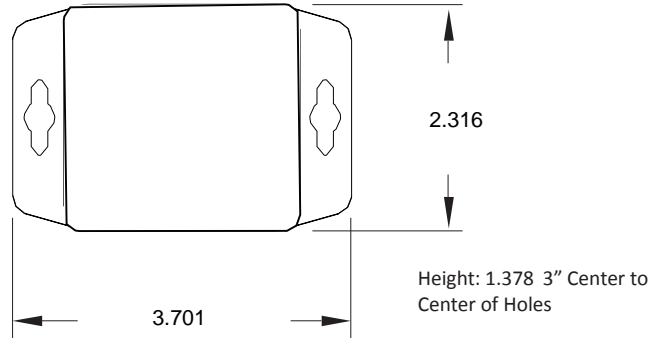

Pic. 2 - Industrial Housing IP65

Part Number Configuration

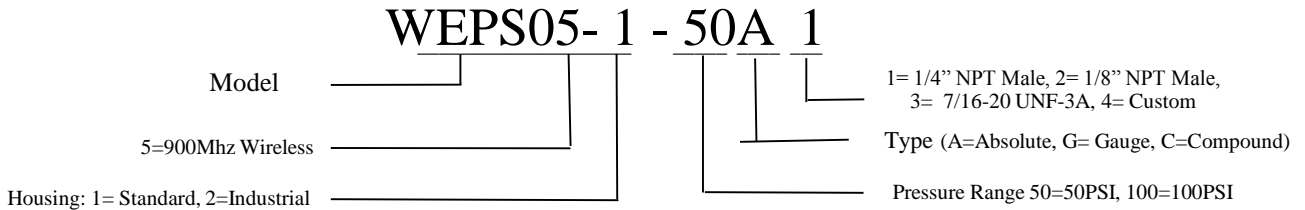

Ph: (480) 269-1665 sales@PhoenixSensors.com

Notice:

Phoenix Sensors LLC reserves the right to make changes to the product contained in this publication. Phoenix Sensors LLC assumes no responsibility for the use of any circuits described herein, conveys no license under any patent or other right, and makes no representation that the circuits are free of patent infringement. While the information in this publication has been checked, no responsibility, however, is assumed for inaccuracies.

Phoenix Sensors LLC does not recommend the use of any of its products in life support applications where the failure or malfunction of the product can reasonably be expected to cause failure of a life-support system or to significantly affect its safety or effectiveness. Products are not authorized for use in such applications.