



- Low Pressure
- Media Isolated –SS316
- -20-125°C Operating Temperature
- Compact Size
- +/- .15% Linearity FS
- Ratio 0.5 - 4.5V, 1-5V, 4-20mA, RS485
- 5-5000 psi pressure ranges
- Absolute or Gage
- Media – Liquid, Air, & Gas
- IP67

DESCRIPTION

The PPT81 is a pressure transducer manufactured for a high operating temperature range for the most challenging of applications. This silicon pressure transducer was designed for industrial and commercial applications. The stainless steel design and high temperature analog component selection allows the sensor to be used in high temperature applications.

The PPT81 series utilizes MEMS piezo-resistive sensors pressurized on the passive backside of the SS housing which has superior long term stability and accuracy (.15% Linearity).

The design is simple, cost effective, and proves reliable for OEM customers. Please contact us for Custom design availability.

APPLICATIONS

- Consumer products
- Industrial Automation
- HVAC
- Automotive Engine
- Compressor
- Pneumatic

Maximum Environmental Ratings

Operating Temperature -20°C to 125°C
 Storage Temperature Range -40°C to 125°C

Proof pressure 3x full scale pressure
 Burst pressure 5x full scale pressure

PPT81 Operational Specifications

V ₊ = 5V, V ₋ = 0V, Temperature = 25°C					
PARAMETER	SYMBOL	MIN	TYP	MAX	UNITS
Supply Voltage (Note 1)	V _{DD}	4.75	5	5.25	V
Supply Current	I _{DD}	.25	1	1.5	mA
Upper Output Voltage (Note 1)	V _{OUT}		4.5	5.2	V
Lower Output Voltage	V _{OUT}	.18	.5		V
Linearity (Note 2)		-0.15		0.15	%FS
Temperature Error (Null and Span) (Note 3)		-1		+1	%FS
Response Time	t _R		1	10	ms
Total Error Band (Note 4)		-0.25		.25	%FS
Compensated Temperature Range	C	0		50	C
Operating Temperature Range	C	-25		125	C
Vibration	G	+-20g, MIL-STD-810C, 514-2			G
Shock	G	30G, 11msec, MIL-STD-202G, Method 213B, Cond A			G

Notes:

- 1) Measured with Supply Voltage at 5V. Output is ratiometric. 9-30V Supply option available for OEM customers. 2) Defined as best straight line 3) Measured from 0°C to 70°C
4) Measured over compensated temperature range -25-85C

Application Information

Package

The one piece body design is made of stainless steel (SS316L), which allows for easy manufacturability and long term stability. Automotive grade vibration proof design for engine mount.

Stability

The silicon MEMS pressure sensor element is mounted to a ceramic base and sealed into the SS housing. The selection of thermally capability materials reduce the mechanical stress on the sensor resulting in greater stability over time and temperature.

Additional stability is gained from factory stabilization of all sensors.

Pressure port

1/4" -18NPT and 1/8"-18NPT threads are standard SS fittings. Other port fittings such as 7/16-20UNF, and 1/4" BSP are available for OEM customers.

Media

The pressure port is tolerant to most media including but not limited to oil, air, gas, some corrosive media, and salt water.

Wetted parts

When checking media capability, the wetted surface is composed of only stainless steel (316).

Pressure ranges

Standard pressure ranges are 50, 100, 150, 200, and 300 psi in absolute and gage. Custom pressure ranges are available for OEM customers.

PPT81-CBL-5ft-1 Color Code



PPT81-CBL-5ft-2 Color Code

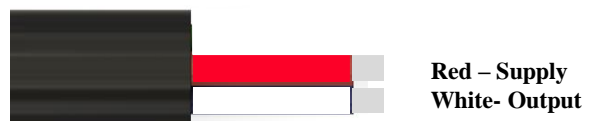

Mechanical Dimensions (inches)

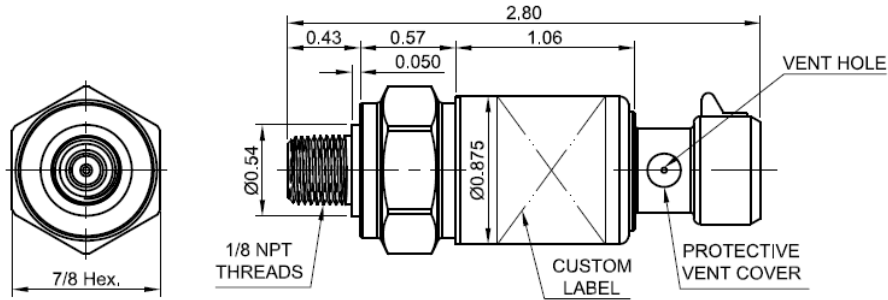

Electrical Connections

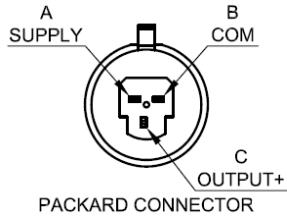

.5-4.5V/1-5V Output Connection

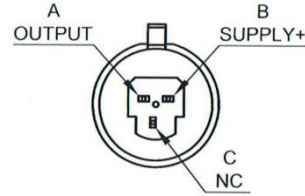

4-20mA Output Connection

Part Number Configuration

PPT81-0 – 50 A 1 1

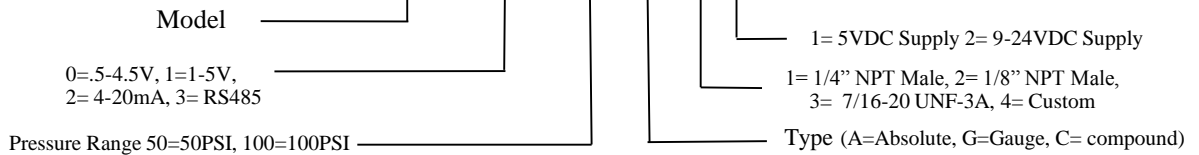

Standard Part Numbers

Model	Pressure Range PSI	Type	Max Over Pressure
PPT81-0-50A1	50	Abs/Gage	150
PPT81-0-100A1	100	Abs/Gage	300
PPT81-0-300A1	300	Abs/Gage	900

Ph: (480) 462-1810 sales@PhoenixSensors.com

Notice:

Phoenix Sensors LLC reserves the right to make changes to the product contained in this publication. Phoenix Sensors LLC assumes no responsibility for the use of any circuits described herein, conveys no license under any patent or other right, and makes no representation that the circuits are free of patent infringement. While the information in this publication has been checked, no responsibility, however, is assumed for inaccuracies.

Phoenix Sensors LLC does not recommend the use of any of its products in life support applications where the failure or malfunction of the product can reasonably be expected to cause failure of a life-support system or to significantly affect its safety or effectiveness. Products are not authorized for use in such applications.