



- -40 – 150°C Operating Temperature
- Compact Size- .354 Hex (9 MM)
- +/- .15% Linearity FS
- Analog (.5-4.5V)
- 10 - 300 psi pressure ranges
- Absolute or Sealed Gage
- Media – Liquid, Air, & Gas

DESCRIPTION

The PPT71 is the smallest transducer in the market with a high temperature range for the most challenging of applications. Phoenix Sensors's unique patented temperature compensation enables superior performance at wide operating temperatures. This silicon pressure transducer was designed for demanding industrial and commercial applications. The stainless steel port design allows for pressure measurement of liquid or gas media.

The PPT71 series utilizes piezo-resistive pressure sensor pressurized packaged in a stainless steel housing which has superior long term stability and accuracy (.15% Linearity).

The two piece design is simple and proves valuable for OEM customers. Please contact us for Custom design availability.

APPLICATIONS

- Mil/Aero
- Industrial Automation
- Automotive Engine
- Compressor
- Pneumatic

Maximum Environmental Ratings

Operating Temperature -40°C to 150°C
 Storage Temperature Range -55°C to 150°C

Proof pressure 3x full scale pressure
 Burst pressure 5x full scale pressure

PPT71 Operational Characteristics

$V_+ = 5V$, $V_- = 0V$, Temperature = 25°C

PARAMETER	SYMBOL	Min	Typ	Max	UNITS
Supply Voltage	V_{DD}	2.8	5	5.5	V
Supply Voltage (Option 2)	V_{DD}	2.8	3	5.5	V
Operating Temperature	T_s	-40		125	C
Supply Current	I_{DD}		<3		mA
Output Voltage <small>(Note 1)</small>	V	.5		4.5	V
Accuracy					
Total Error Band <small>(Note 4)</small>		-1.5	.75	1.5	%Full Scan
Non-Linearity <small>(Note 2)</small>		-.15		.15	%Full Scan
Response Time	t_R	5	25	200	ms

Notes:

1) Analog Output option is ratiometric to the supply voltage 2) Measured at zero pressure. 3) Defined as best straight line 4) Measured from -20°C to 85°C

Application Information

Package

The one piece body design is made of stainless steel (SS316L), which allows for easy manufacturability and long term stability. The SS is highly impervious to corrosion and rust.

Stability

The silicon MEMS pressure sensor has a Pyrex base and is mounted to a ceramic substrate and sealed into the SS housing. Flexible die attach materials help reduce the mechanical stress which results in greater stability over time and temperature.

Additional stability is gained from factory stabilization of all sensors.

Pressure port

10-32 UNF-2A is the standard port located at the base of the sensor. Other port fittings are available for OEM customers.

Media

The pressure port is tolerant to most media including but not limited to oil, air, gas, some corrosive media, and salt water.

Wetted parts

The wetted surfaces are composed of stainless steel, Viton, and silicon.

Pressure ranges

Standard pressure ranges are 15, 30, 50, 100, 150 psig. Custom pressure ranges are available for OEM customers.

Wiring

Analog Output - Red: +V, Black: Gnd, White: Output

Digital Output – Red: +V, Black: Gnd, White: SCL/SCLK

Green: SDA/MISO , Yellow: SS/INT

26 gauge wire

Mechanical Dimensions (inches)

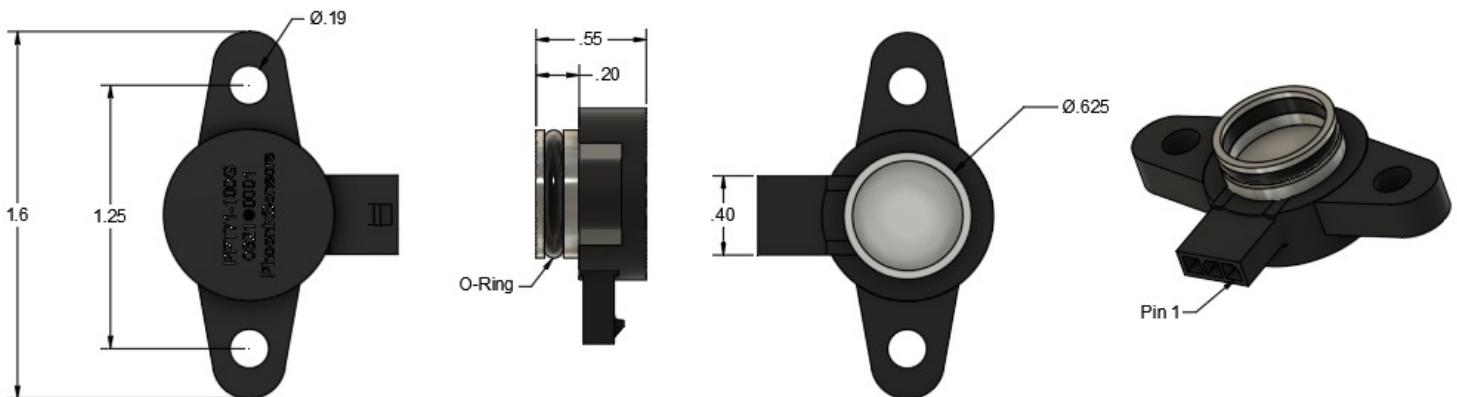

Electrical Connections	
Pin #	Action
1	SUPPLY+
2	SUPPLY-
3	OUTPUT

Part Number Configuration

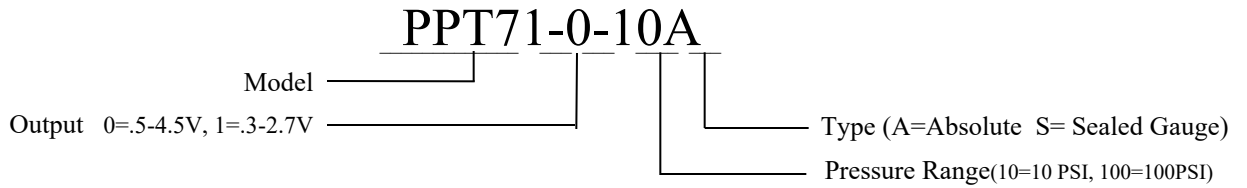

*Note: Output option 1 only available with 3V input

Standard Part Numbers

Model	Pressure Range PSI	Type	Max Over Pressure
PPT71-0-10A	10	Abs/Gage	30
PPT71-0-30A	30	Abs/Gage	90
PPT71-0-50A	50	Abs/Gage	150
PPT71-0-100A	100	Abs/Gage	250

Ph: (480) 462-1810 sales@PhoenixSensors.com

Notice:

Phoenix Sensors LLC reserves the right to make changes to the product contained in this publication. Phoenix Sensors LLC assumes no responsibility for the use of any circuits described herein, conveys no license under any patent or other right, and makes no representation that the circuits are free of patent infringement. While the information in this publication has been checked, no responsibility, however, is assumed for inaccuracies.

Phoenix Sensors LLC does not recommend the use of any of its products in life support applications where the failure or malfunction of the product can reasonably be expected to cause failure of a life-support system or to significantly affect its safety or effectiveness. Products are not authorized for use in such applications.