



FEATURES

- Low or High Pressure (1-15,000 PSI)
- Media Isolated –SS316
- Low-Profile
- 5 MS Response Time
- 1% Total Error Band Pressure (.15% Option)
- Analog Output
- IP65 (IP67 option)
- Media – Harsh Liquid, Air, & Gas

DESCRIPTION

The PPT83 is an analog pressure transducer manufactured for a high operating temperature range for the most challenging of applications. The unique design allows for pressure measurement of the media with fast-response time. This silicon pressure transducer was designed for industrial and commercial applications. The stainless-steel design and analog component selection allows the sensor to be used in a variety of applications.

The PPT83 series utilizes MEMS piezo-resistive sensors pressurized on the passive backside of the SS housing which has superior long-term stability and accuracy (.25% Linearity).

The design is simple, cost effective, and proves reliable for OEM customers. Please contact us for Custom design availability.

APPLICATIONS

- Mil/Aero
- Industrial Automation
- HVAC
- Automotive Engine
- Compressor
- Pneumatic

Maximum Environmental Ratings

Operating Temperature	-40°C to 125°C	Proof pressure	3x full scale pressure
Storage Temperature Range	-55°C to 130°C	Burst pressure	5x full scale pressure

Package

The one-piece body design is made of stainless steel (SS316L), which allows for easy manufacturability and long-term stability. Automotive grade vibration proof design for engine mount.

Stability

The silicon MEMS pressure sensor element is media isolated and hermetically sealed into the SS housing. The selection of thermally capability materials reduce the mechanical stress on the sensor resulting in greater stability over time and temperature.

Additional stability is gained from factory stabilization of all sensors.

Pressure port

1/4" -18NPT and 1/8"-18NPT threads are standard SS fittings. Other port fittings such as 7/16-20UNF, and 1/4" BSP are available for OEM customers.

Media

The pressure port is tolerant to most media including but not limited to oil, air, gas, some corrosive media, and salt water.

Wetted parts

When checking media capability, the wetted surface is composed of only stainless steel (316).

Pressure ranges

Standard pressure ranges are 100, 300, 500, 1000, 1500, 3000, 5000, and 10,000 psi in absolute and gage. Custom pressure ranges are available for OEM customers.



PPT83 Analog Output Operational Characteristics

V ₊ = 5V, V ₋ = 0V, Temperature = 25°C					
PARAMETER	SYMBOL	MIN	TYP	MAX	UNITS
Supply Voltage	V _{DD}	4.75	5	32	V
Supply Current	I _{DD}	.25	1	1.5	mA
Linearity (Note 2)		-0.25		0.25	%FS
Response Time	t _R		5	10	ms
Total Error Band (Note 4)		-1		1	%FS
Compensated Temperature Range	C	-40		85	C
Operating Temperature Range	C	-40		125	C
Accuracy (Total Error Band)	±%FS	-1	0.5	1	±%FS

Notes: 1) Measured at zero pressure. 2) Defined as best straight line 3) Measured from 0°C to 70°C.

Electrical Pin Configuration (Analog)



Red - V+In
White - Analog Output
Black - GND

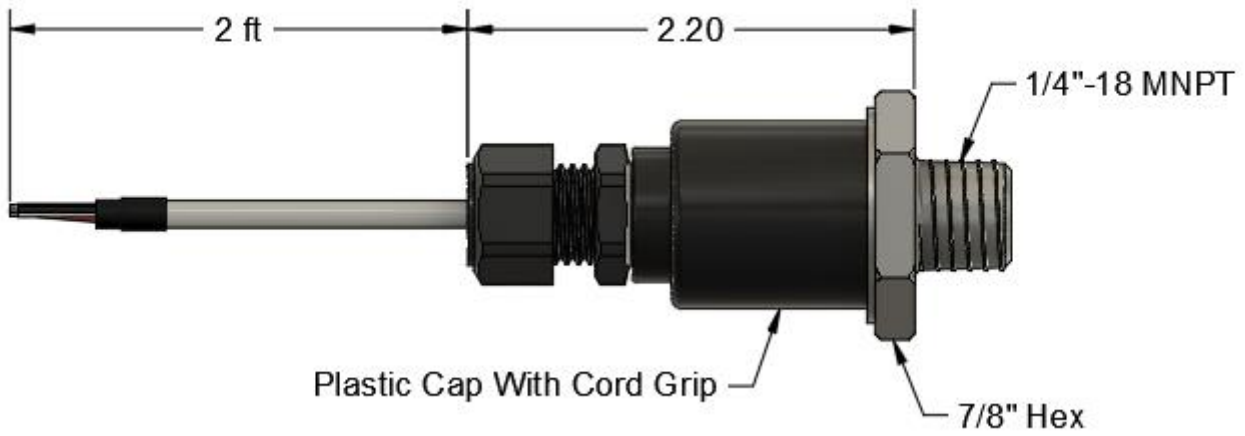

Figure 1 (IP67)

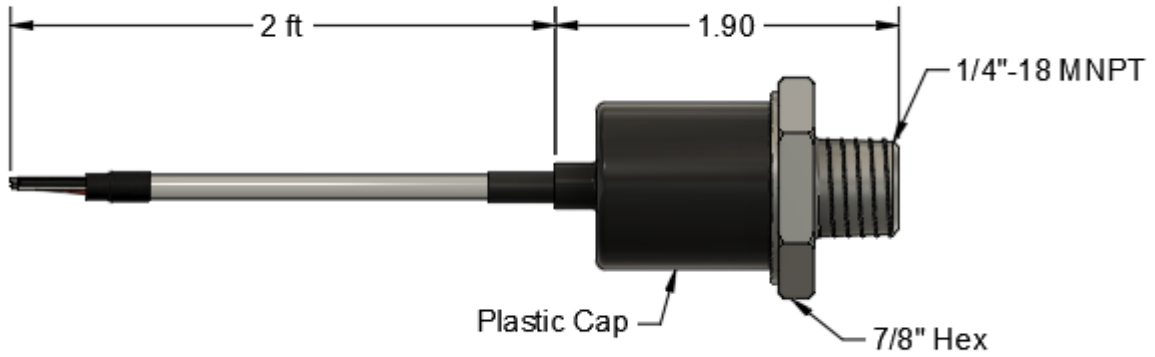
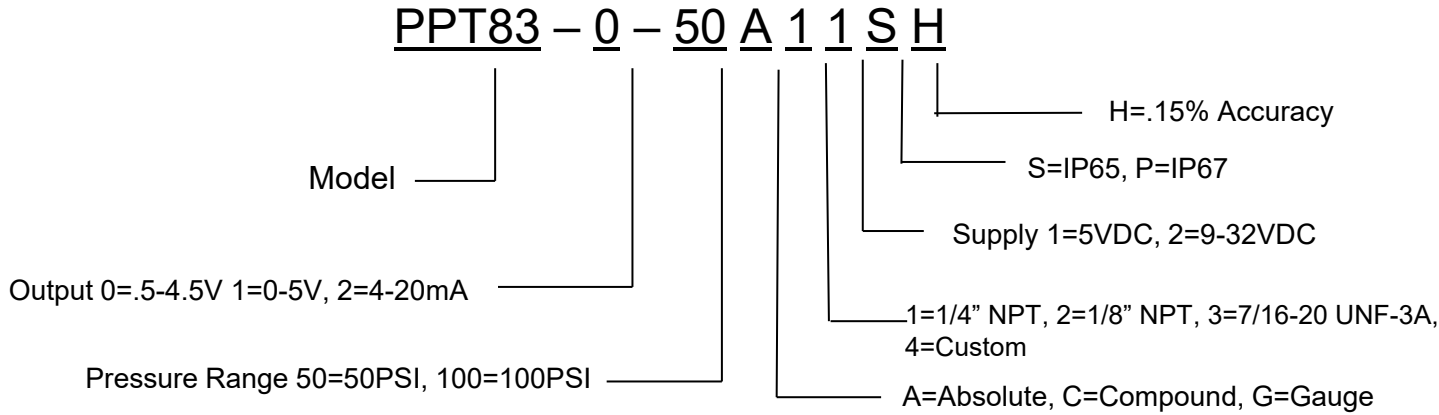

Figure 2 (IP65)

NOTE: Standard Cable Length 24" (2Ft)

Part Number Configuration



Example Part Numbers

Model	Pressure Range PSI	Type	Max Over Pressure
PPT83-0-50A	50	Gauge	150
PPT83-0-100A	100	Gauge	300
PPT83-0-300A	300	Gauge	900

Ph: (480) 462-1810 sales@PhoenixSensors.com

Notice:

Phoenix Sensors LLC reserves the right to make changes to the product contained in this publication. Phoenix Sensors LLC assumes no responsibility for the use of any circuits described herein, conveys no license under any patent or other right, and makes no representation that the circuits are free of patent infringement. While the information in this publication has been checked, no responsibility, however, is assumed for inaccuracies.

Phoenix Sensors LLC does not recommend the use of any of its products in life support applications where the failure or malfunction of the product can reasonably be expected to cause failure of a life-support system or to significantly affect its safety or effectiveness. Products are not authorized for use in such applications.